

SPLITTER GEARBOX FOR PUMPS WITH EUROPEAN UNIFIED FLANGE / SAE / ISO

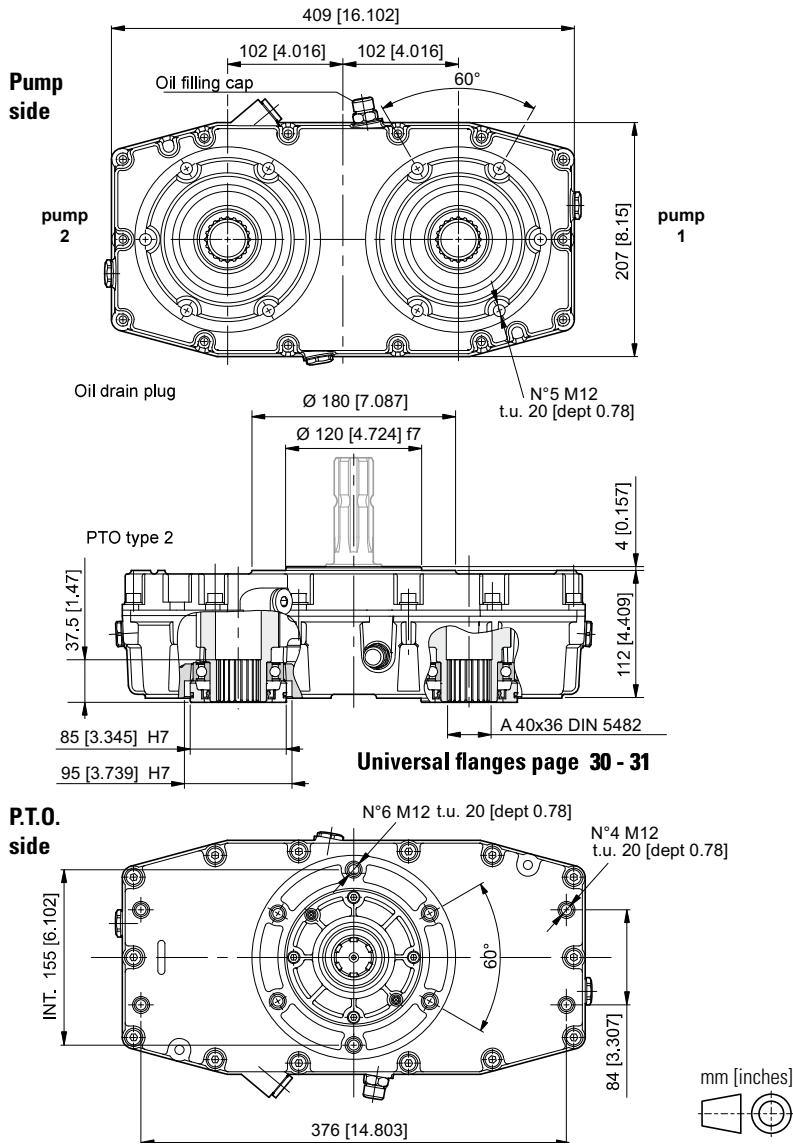

P.T.O.

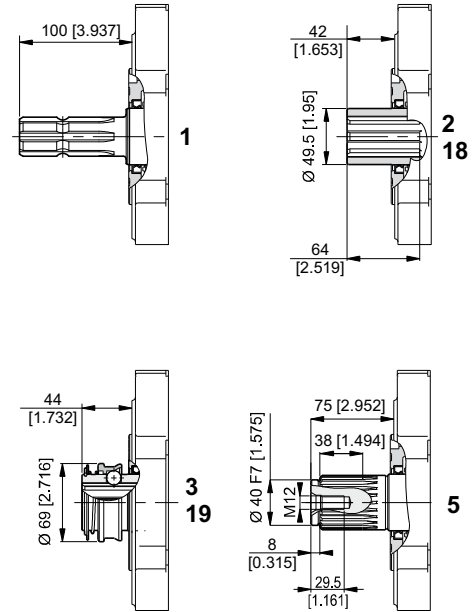

Mounting positions

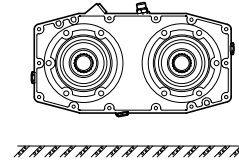

ORDERING CODE

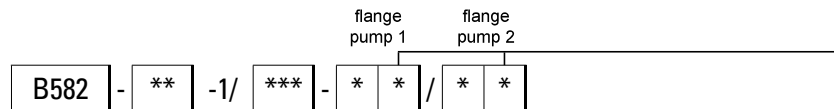

B502 = Splitter gearbox (aluminium body)

P.T.O.

- 1 = Male 1" 3/8 DIN 9611
- 2 = Female 1" 3/8 DIN 9611
- 3 = Female 1" 3/8 DIN 9611 + tightening
- 5 = Male Z23 DIN 5482
- 18 = Female z21 - 16/32 DIN 9611
- 19 = Female z21 - 16/32 DIN 9611 + tightening

Coupling for pump to be required to our sales department.

Type (see page 30 - 31)	Flange position	
	1	2
D / G ⁽¹⁾		
E / F		
A / B / C / L / M	—	

⁽¹⁾ G1 only on pump 2 - G2 only on pump 1

Transmission ratio

1 = 1 : 1.0	3 = 1 : 3.0
1,5 = 1 : 1.5	3,4 = 1 : 3.4
2 = 1 : 2.0	4 = 1 : 4.0
2,6 = 1 : 2.6	4,8 = 1 : 4.8

TECHNICAL DATA

Transmission ratio	Maximum torque Nm [lbf-ft]				Weight kg [lb]
	540 rpm		1000 rpm		
	C1*	C2*	C1*	C2*	
1 : 1.0	885 [655]	466 [344]	866 [639]	456 [336]	16 [35.3]
1 : 1.5	608 [448]	320 [236]	589 [434]	310 [229]	15,5 [34.2]
1 : 2.0	460 [339]	242 [178]	441 [325]	232 [171]	14,6 [32.2]
1 : 2.6	342 [252]	180 [133]	323 [238]	170 [125]	14,6 [32.2]
1 : 3.0	310 [228]	163 [120]	—	—	13,7 [30.2]
1 : 3.4	257 [190]	135 [100]	—	—	15,1 [33.3]
1 : 4.0	224 [165]	118 [87]	—	—	14,8 [32.6]
1 : 4.8	186 [137]	98 [72]	—	—	17,45 [38.5]

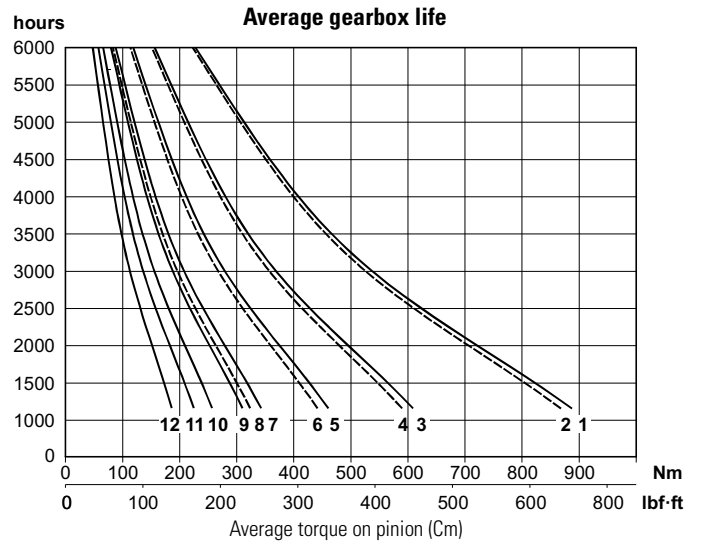

* Maximum torque on pump:
C1= maximum starting torque; C2= maximum torque for continuous duty.

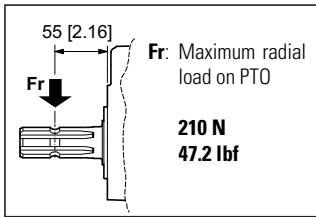

Oil
liters [US gallon]
1.70 [0.45]

Input rpm	Output (transmission ratio)								
	1 : 1.0	1 : 1.5	1 : 2.0	1 : 2.6	1 : 3.0	1 : 3.4	1 : 4.0	1 : 4.8	
540	curve	1	3	5	7	9	10	11	12
	rpm	540	810	1080	1408	1620	1836	2160	2592
1000	curve	2	4	6	8	—	—	—	—
	rpm	1000	1500	2000	2607	—	—	—	—

SPARE PARTS

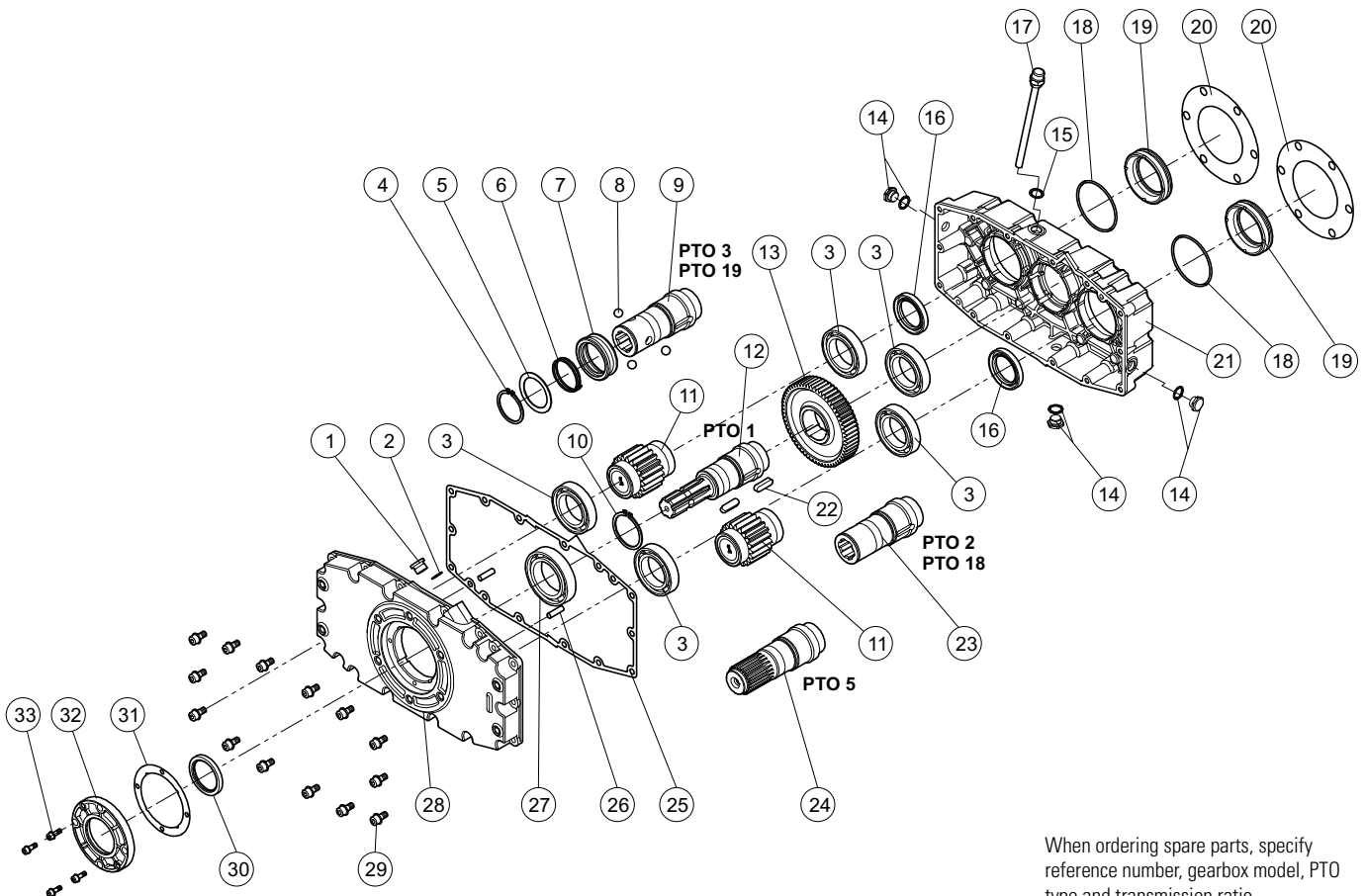

When ordering spare parts, specify reference number, gearbox model, PTO type and transmission ratio.